

Pin Electronics Card

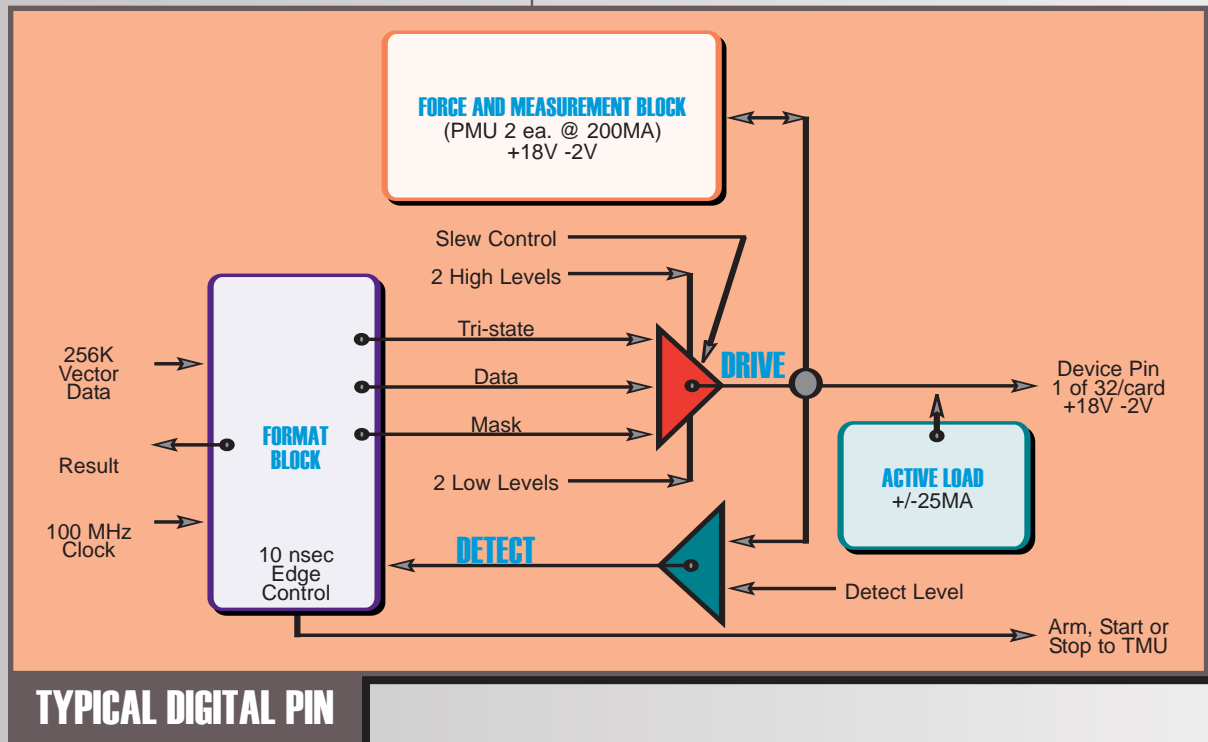

TYPICAL DIGITAL PIN

Full featured and mechanically robust, advanced test products from Telco Testing Solutions are designed to provide extremely high throughput and rock bottom cost of ownership.

PIN DRIVER SPECIFICATION

The Digital Pin Electronics Resources provide up to 64 digital signal pins. Each digital pin consists of a driver, a comparator and an active load. Functional NRZ patterns of up to 256K vectors may be executed at rates from 50 kHz to 50 MHz. The vector sequencer supports looping, branching, nested subroutines and connections to the TMU resource. All opcodes are supported from 50 kHz to 6.25 MHz. Patterns running at frequencies above 6.25 MHz utilize a standard straight-line execution approach. A unique timeset implementation significantly reduces the number of vectors in a typical program. There are four groups of 16 different timesets available on-the-fly. Each timeset can

contain up to 512 edges. The timesets provide edge timing in 10 ns, 20 ns, 40 ns and 80 ns increments. There are two parametric measurement units (PMUs) for each group of 32 pins. The PMUs are full 4-quadrant voltage/current forcing supplies capable of forcing up to 200 mA at -2 V to +18 V over 7 current ranges and 1 voltage range. Either PMU can be connected to any of the 32 digital pins.

- Maximum NRZ Data Rate 50 MHz (mux or non-mux)
- Maximum Output Current +/- 30 mA
- Driver Output Impedence 50 Ohms
- Force Accuracy (Unloaded) +/- 1% of val +/-50 mV
- Output Overshoot 3% + 50 mV
- Slew Rate (Programmable) 1 V/ns to 0.2 V/ns
- Driver Force Range -3 V to +18 V (6 mV res)
- Tri-state Leakage +/- 100 mA max
- Pin with Driver Off Leakage +/- 20 nA
- Minimum Amplitude 200 mV

VOLTAGE COMPARATOR SPECIFICATION

Comparators can accept either a standard reference input voltage or an external voltage reference.

- Maximum Input Offset Error 5 mV; 1 mV typical
- Maximum Data Rate 50 MHz
- Operating Voltage Range -3 V to +18 V (10 mV res)
- Absolute Accuracy +/-20 mV; +/-6 mV typical
- Input Bias Current (Input Disabled) +/-1 nA
- DC Pin Capacitance 15 pF

ACTIVE LOAD SPECIFICATION

There are three global sets of active load values. Each pin can independently select one of the three value sets. Active loads have individual, independent tri-state capability.

- IOL Current Range 0 mA to 25 mA (6 uA res)
- IOH Current Range -25 mA to 0 mA (6 uA res)
- IOH/IOL Accuracy +/-5% of value +/- 20 uA
- IOL Operating Range -5 V to +18 V
- IOH Operating Range -5 V to +18 V
- VTT Operating Range -3 V to +17.5 V (5 mV res)
- VTT Accuracy +/-200 mV
- Tri-state Leakage +/-20 nA

PARAMETRIC SPECIFICATION

- There are two PMUs for each group of 32 pins. Either or both of these PMUs may be connected to any digital DUT pin.
- The PMUs are capable of forcing voltage and measuring current, or forcing current and measuring voltage. (Four quadrant voltage/current force operation.)
- The PMUs have tri-state capability.
- The PMUs have differential measurement capability.
- The PMUs have 7 current ranges in decade sequence, from 200 nA to 200 mA (200 nA, 2 uA, 20 uA, 200 uA, 2 mA, 20 mA, 200 mA), and one voltage range: -2 V to +18 V.
- Both PMUs are capable of being ganged to force and measure up to 400 mA.
- Current Force Accuracy +/- (0.1% value + 0.1% FS + 20 nA)
- Current Measure Accuracy +/- (0.1% value + 0.1% FS + 20 nA)
- Voltage Force Accuracy +/- 0.1% value +/- 10 mV
- Voltage Measure Accuracy +/- 0.1% value +/- 10 mV
- Differential Voltage Measurement Accuracy +/- 0.25% value +/- 5 mV
- Voltage Range -2 V to +18 V
- Current Ranges 200 nA, 2 mA, 20 uA, 200 uA, 2 mA, 20 mA, 200 mA
- Max Current/DUT pin +/- 200 mA
- Pin Leakage +/- 20 nA
- Voltage Clamp Range (Forcing Current) -3 V to + 18 V
- Voltage Clamp Accuracy +/- 1 V

wide operating voltage range

SERVICE AND SUPPORT

Telco Testing Solutions offers a full line of service and support that can be tailored to the specific needs of the engineering and manufacturing segments of your business. We offer on-line technical support, in-house training, service contracts, regional or on-site customer service, and a host of other options. Our goal is to keep your system fully productive! See your Telco Testing Solutions Customer Service representative for more details.



4670 South Ash Avenue
 Tempe, Arizona 85282 (USA)
 480-603-1828
 866-547-3507 toll free
 480-603-3003 fax

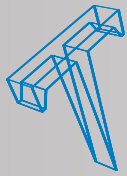

TELCO
TESTING SOLUTIONS, LLC

Low Current VI Card

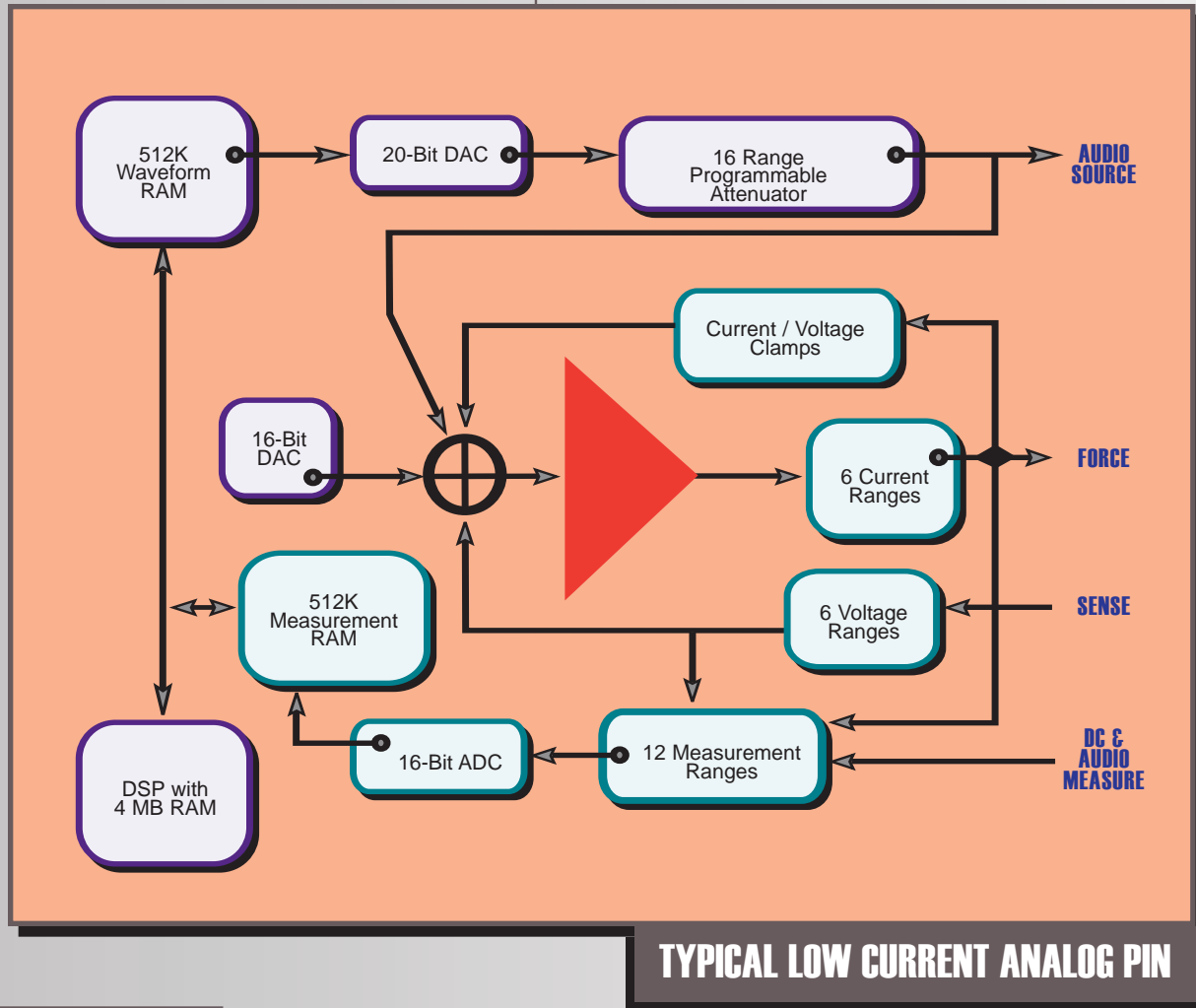

TYPICAL LOW CURRENT ANALOG PIN

Full featured and mechanically robust, advanced test products from Telco Testing Solutions are designed to provide extremely high throughput and rock bottom cost of ownership.

PARAMETRIC SPECIFICATION

The low-current VI contains six 4-quadrant voltage/current sources on each resource card. Voltage force is +/-100 V maximum when installed in a MST and 30 V maximum when installed in a MiSTEC. Each source can supply up to 500 mA @ 100% duty cycle. Many backplane configurations are possible to meet user resource requirements. The present backplane supports four low-current VI resource cards for a total of 24 low-current VI sources. Parallel sources are supported. A DSP sub-system provides waveform generation and measurement capability. The programmable arbitrary waveform resolution is 64K steps using 20-bit values with a maximum clock rate of 500KHz.

- Voltage Force (maximum)
+/-100 V (MST) +/-30 V (MiSTEC)
- Voltage Ranges & Accuracy
+/-2 V +/-(.05% val + 0.03% range)
+/-5 V +/-(.05% val + 0.03% range)
+/-10 V +/-(.05% val + 0.03% range)
+/-20 V +/-(.05% val + 0.03% range)
+/-50 V +/-(.05% val + 0.03% range)
+/-100 V +/-(.05% val + 0.03% range)
- Current Force (maximum)
500 mA +/-100 V compliant

supports parallel sources

- Range Accuracy

500 mA	0.2% FS + 0.1% val
50 mA	0.1% FS + 0.1% val
5 mA	0.1% FS + 0.1% val
500 uA	0.1% FS + 0.1% val + 20 nA
50 uA	0.1% FS + 0.1% val + 20 nA
5 uA	0.1% FS + 0.1% val + 20 nA
500 nA	0.1% FS + 0.1% val + 20 nA

- Compliance - 1% to 120% of Range

Voltage Force Current Clamp Accuracy	3% of FS	12-bit Res
	100V and 10 V Range (MST)	
	30V and 10 V Range (MiSTEC)	
Current Force Voltage Clamp	3% of FS	12-bit Res

- Programmable Compensation - 8 Selections

Associated Settle Times	
20V/50V/100V	10V/5V/2V
2400 us	240 us
630 us	63 us
150 us	15 us
50 us	
11 us	

DSP Subsystem

- Programmable Waveform Sources

Frequency	DC to 100 kHz
Clock Rate	500 kHz max
Clock Resolution	0.023 Hz
Waveform Resolution	64K Steps, 20-bit Values

Amplitude

0-20 kHz (MiSTEC)	60 V P/P Max (through VI sources)
0-20 kHz (MST)	200 V P/P Max (through VI sources)
>20 kHz	20V P/P (direct to Load Board)
Accuracy	0.1% FS +/- 500 mV
Attenuation	16 Ranges direct to Load Board
16 Ranges	610 mV P/P to 20 V P/P
Resolution	0.5 nV @ 610 uV P/P
	19 mV @ 20 V P/P
THD+N	-85 dB max @ 1 kHz

- Low Frequency Digitizer

Sample Rate	DC to 100 kHz
Sample Precision	16 Bits
Sample Size	64K Steps, 16-bit Values

DC Measurement System

- Voltage Measurement Ranges and Accuracy

+/-100 V	+/- (0.02% val + 0.03% range)
+/-50 V	+/- (0.02% val + 0.03% range)
+/-20 V	+/- (0.02% val + 0.03% range)
+/-10 V	+/- (0.02% val + 0.03% range)
+/-5 V	+/- (0.02% val + 0.03% range)
+/-2 V	+/- (0.02% val + 0.03% range + 500 uV)
+/-1 V	+/- (0.02% val + 0.03% range + 500 uV)
+/-0.5 V	+/- (0.02% val + 0.03% range + 500 uV)
+/-0.2 V	+/- (0.02% val + 0.03% range + 500 uV)
+/-0.1 V	+/- (0.02% val + 0.03% range + 500 uV)
+/-0.05 V	+/- (0.02% val + 0.03% range + 500 uV)
+/-0.02 V	+/- (0.02% val + 0.03% range + 500 uV)

- Current Measurement Ranges, Accuracy

and Settling Time

500 mA	0.2% FS + 0.1% val	
50 mA	0.1% FS + 0.1% val	100 us
5 mA	0.1% FS + 0.1% val	100 us
500 uA	0.1% FS + 0.1% val + 20 nA	200 us
50 uA	0.1% FS + 0.1% val + 20 nA	400 us
5 uA	0.1% FS + 0.1% val + 20 nA	3 ms
500 nA	0.1% FS + 0.1% val + 20 nA	8 ms

many possible backplane configurations

SERVICE AND SUPPORT

Telco Testing Solutions offers a full line of service and support that can be tailored to the specific needs of the engineering and manufacturing segments of your business. We offer on-line technical support, in-house training, service contracts, regional or on-site customer service, and a host of other options. Our goal is to keep your system fully productive! See your Telco Testing Solutions Customer Service representative for more details.



4670 South Ash Avenue
Tempe, Arizona 85282 (USA)
480-603-1828
866-547-3507 toll free
480-603-3003 fax

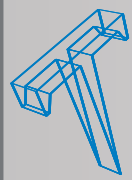

TELCO
TESTING SOLUTIONS, LLC

Time Measurement Unit

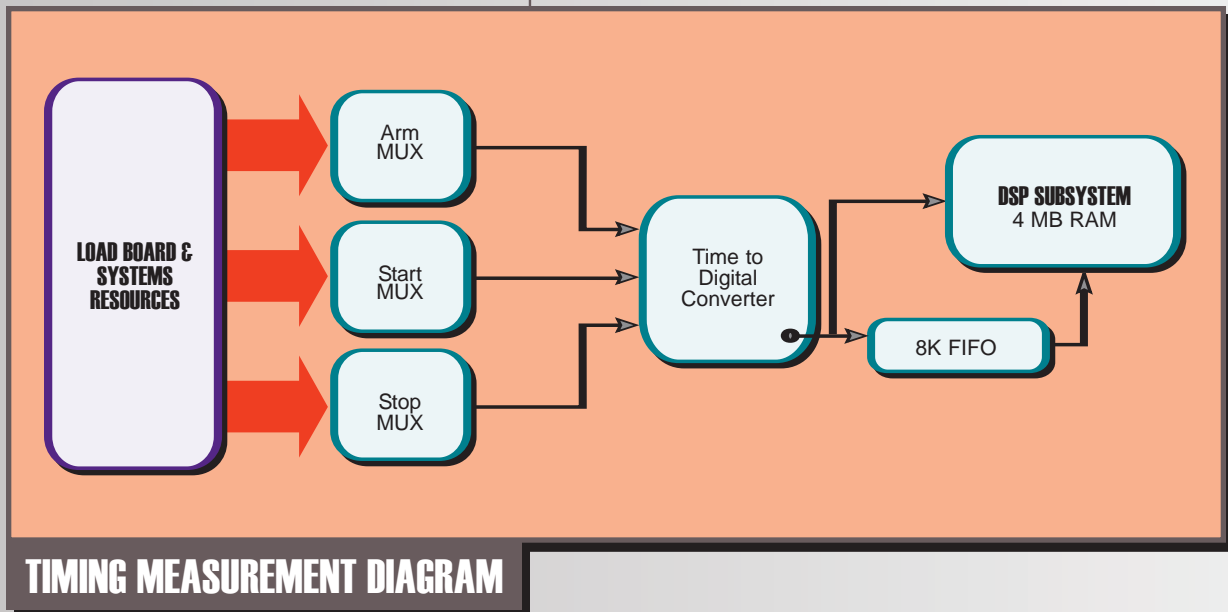

TIMING MEASUREMENT DIAGRAM

Full featured and mechanically robust, advanced test products from Telco Testing Solutions are designed to provide extremely high throughput and rock bottom cost of ownership.

The Time Measurement Unit (TMU) measures time, counts events, or measures the ratio of events in two pulse trains. These can be defined by start and stop events that occur after an arming process.

The TMU is a complete timing unit, and can measure up to 22 minutes with either 20 ps or 625 ps resolution. It can make and store 8K measurements at a 10 MHz rate, and can count two trillion events. The TMU arms, starts and stops measurements based on events from the MST system resources and from the load board. Load board events can be detected by high impedance, high voltage detectors or higher bandwidth 50 ohm detectors.

- **TMU Inputs**
 - 16 Start/Stop detector pairs with 1 MOhm input impedance
 - 1 Arm detector Input with 1 MOhm input impedance
 - 3 Start/Stop detector pairs, 1 Arm, with low-pass filters and 1 MOhm input impedance
 - 4 Start/Stop detector pairs with 50 ohm input impedance
 - 1 Arm detector input with 50 ohm input impedance
 - 2 Start inputs from PE detectors
 - 2 Stop inputs from PE detectors
 - 2 Arm inputs from PE detectors
 - 16 inputs from UTIL/SYNC signals
 - 4 inputs from MPU DDS clocks
- **Input Detectors**

50 Ohm	-2 V to +3 V Input Range
Bandwidth	350 MHz
Input Threshold Accuracy	+/- (0.2% + 5 mV)
1 MOhm	-30 V to 70 V Input Range
Bandwidth	150 MHz
Input Threshold Accuracy	1% +/- 100 mV
Hysteresis Range	0 V to 100 V in hysteresis mode

multiple levels of conditional logic

- Time Interval Mode 50 Ohm HiZ
 - Range/Resolution +/-22 Min/20 ps +/-22 Min/20 ps
 - Accuracy 1 ppm +/- 100 ps 1 ppm +/- 5 ns
 - Channel Skew 200 ps 2 ns
 - Jitter 100 ps 1 ns
 - Rise Time 1 ns 2.3 ns
 - Bandwidth 350 MHz 150 MHz
 - Min Time between Measurements 100 ns 100 ns
- Time Digitizer Mode 50 Ohm HiZ
 - Min Time Width 1 ns 1 ns
 - Max Digitizing Rate 10 MHz 10 MHz
 - Memory Depth 8K 8K
 - Accuracy 1 ppm +/- 100 1 ppm +/- 5 ns
 - Channel Skew 200 ps 2 ns
 - Jitter 100 ps 1 ns
- Event Counter Mode
 - Data Rate 350 MHz
 - Max Count 41 bits
- Ratio Counter Mode 1 ppm
- Gating
 - Arm process:
 - Wait for Arm detector event +/- edge, or Always Armed
 - Then wait for 0 to 4 Million edges of A or B +/- edges
 - Then wait for 0 to 5 ms time, 1.25 ns res, 1ppm +/- 2 ns accuracy
 - Then Arm now or wait for A or B, +/- edge

- synchronous Arm
- Start Process
 - Wait for Arm,
 - Wait for holdoff for 0 to 255 edges of A or B, +/- edges
 - Then Start on A or B, +/- edge
- Stop Process
 - Wait for Arm,
 - Wait for holdoff for 0 to 1 Million edges of A or B, +/- edges
 - Then stop on A or B, +/- edge
- Supported Measurements include
 - Period/Freq/Duty Cycle
 - Rise Time/Fall Time/Pulse Width
 - Prop Delay/Event/Ratio
 - Multiple Measurements (average, min - max)
 - Single Event Rise Time
- High Voltage Drivers on TD Board
 - Number of Drivers 4
 - Programmable Slew Rate 0.2 V/ns to 1 V/ns
 - Programmable
 - High & Low Levels +/- 10 V, 12-bit Res., 0.2 V Min. Amp.
 - Output Current 50 mA Max

+/- 22 minute range at 20 ps resolution

SERVICE AND SUPPORT

Telco Testing Solutions offers a full line of service and support that can be tailored to the specific needs of the engineering and manufacturing segments of your business. We offer on-line technical support, in-house training, service contracts, regional or on-site customer service, and a host of other options. Our goal is to keep your system fully productive! See your Telco Testing Solutions Customer Service representative for more details.



4670 South Ash Avenue
 Tempe, Arizona 85282 (USA)
 480-603-1828
 866-547-3507 toll free
 480-603-3003 fax

Dead Bug Testing of CMOS Image Sensors

The MiSTEC Tightly Coupled Vision Cell supports dead bug orientation for testing CMOS Image Sensors. The internal mechanism of the cell provides tightly coupled resources to verify the optical properties of the sensors.

The primary resource is a sophisticated light source. The luminance and chrominance of the light may be controlled from within the test program. Both the chrominance and luminance may be changed under device program control in less than 100 ns. The distance of the light source from the device under test may also be adjusted automatically.

A secondary resource is a turret that will rotate between positions in less than 100 ms also under device program control.

There are five positions on the turret that accommodate standard 25mm optical components such as IR cutoff filters, holographic diffusers, ground glass diffusers, dichroic filters, neutral density filters, etc.

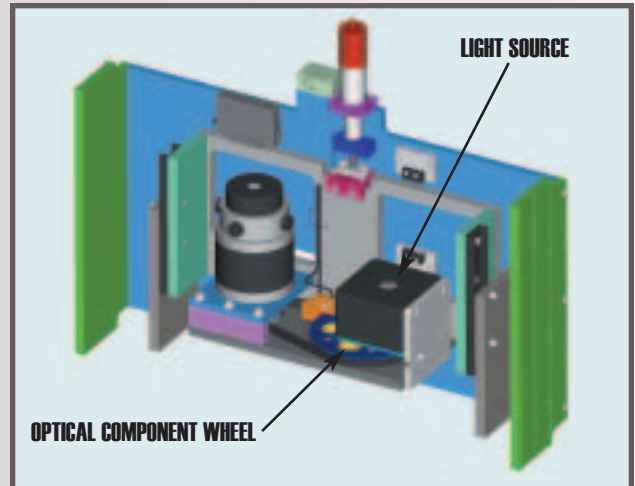

Cell Machinery

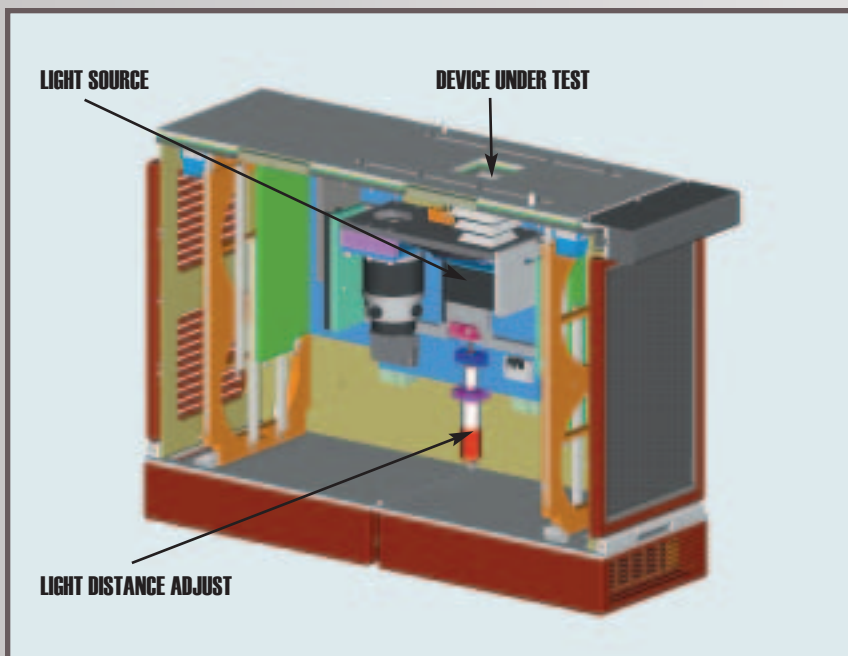

Cross Section of Tightly Coupled Vision Cell

tightly coupled image processing

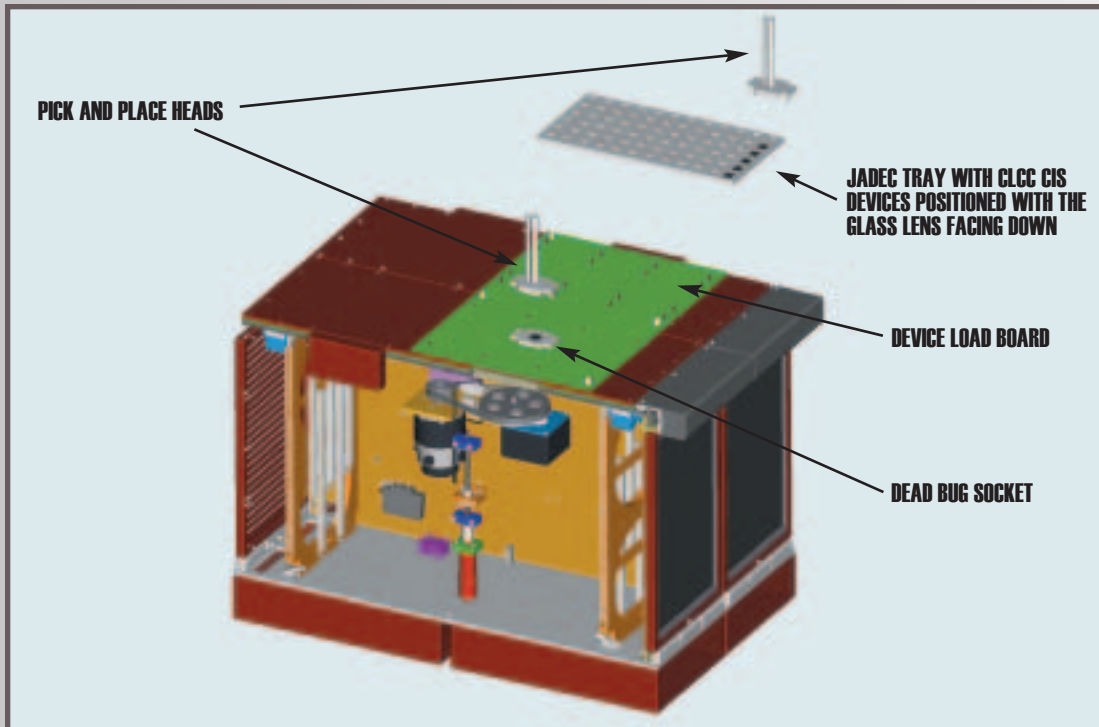

MiSTEC Tester with Tightly Coupled Vision Cell in the Dead Bug Test Configuration

test program controls chrominance and luminance

The small size of the light source allows it to be positioned in close proximity to the dead bug socket. The pick and place heads remove the device from the tray without contacting the top of the package, and place it into the socket. The vacuum cup of the pick and place head makes contact with the back of the CLCC device. The light chrominance is created from three programmable sources.

	Frequency	Irradiance
Source 1(Red)	660 nm	0 to 25000 nW/cm ²
Source 2(Green)	525 nm	0 to 10000 nW/cm ²
Source 3(Blue)	468 nm	0 to 20000 nW/cm ²
Source 4(White)		0 to 50000 nW/cm ²

Luminance of each source is selectable from full-off to full-on in 65,000 steps. Mixing the luminance of the three sources will produce a wide spectrum of color and intensity with a uniformity within 2% across the dead bug socket site. Added diffusion components on the optics wheel will further enhance uniformity. All aspects of the light source are variable from within the device program (tightly coupled) and can be changed within a 100 ns time span.



4670 South Ash Avenue
Tempe, Arizona 85282 (USA)
480-603-1828
866-547-3507 toll free
480-603-3003 fax